



REV: MDL 05/04/12

©ROMEYN DESIGNS, INC. 2012

## MONTEREY - A

BAY WINDOW OPTION

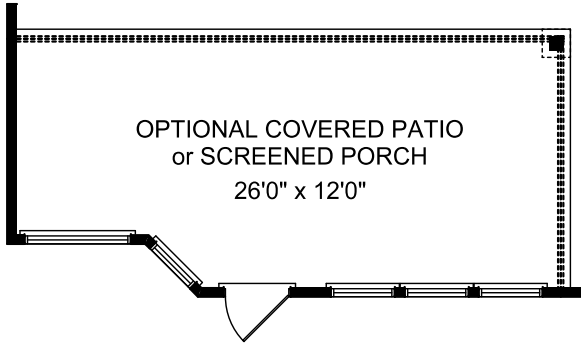
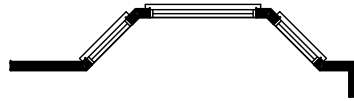

OPTIONAL COVERED PATIO  
or SCREENED PORCH  
26'0" x 12'0"

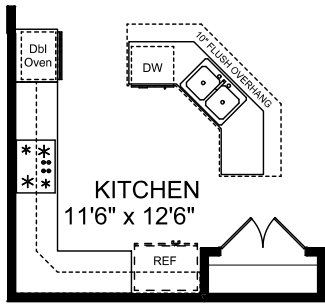

GOURMET KITCHEN  
OPTION

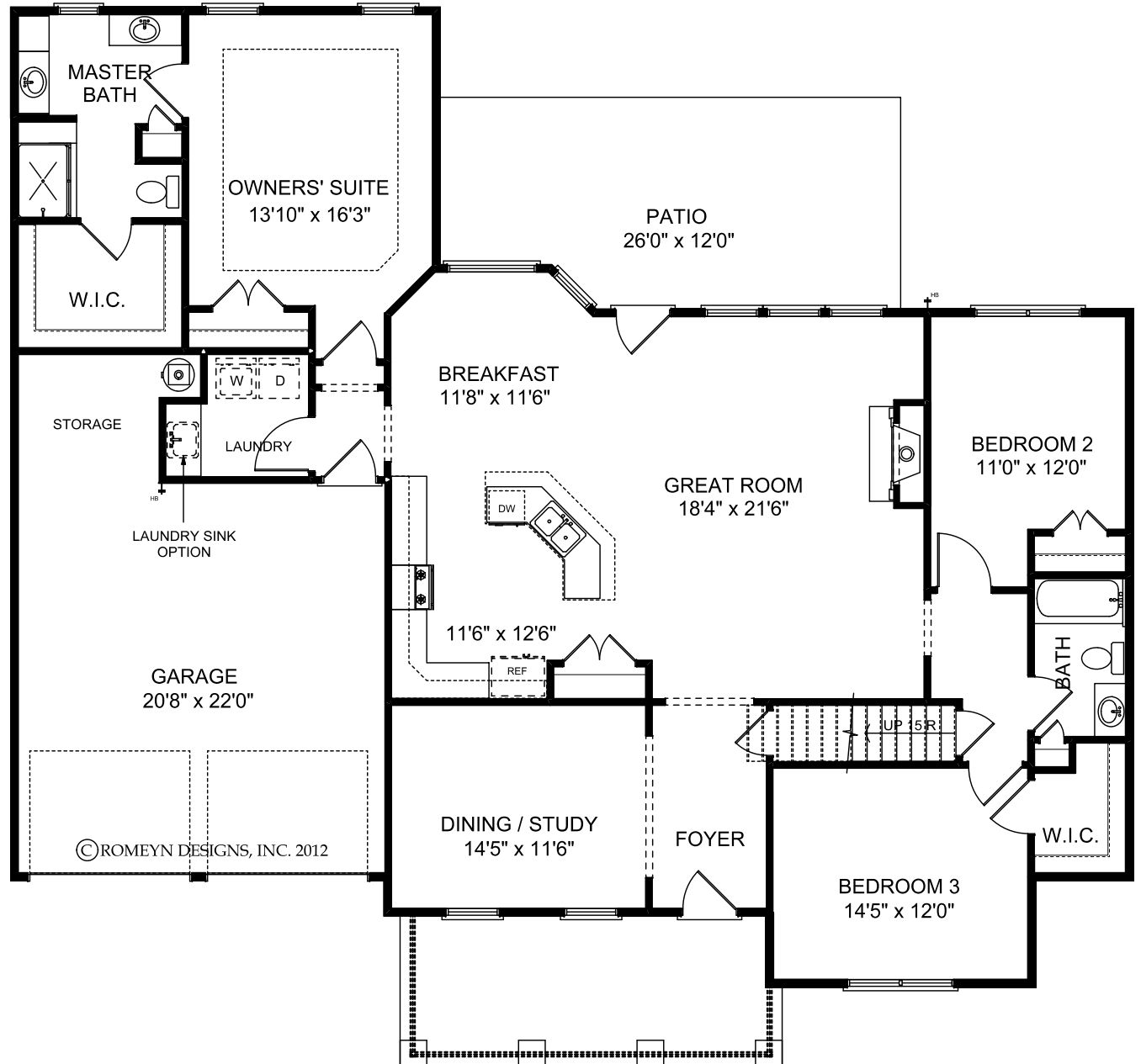

# MONTEREY - A

HEATED - 2072 SQ. FT.  
ATTIC FLOOR - 224 SQ. FT.  
GARAGE - 528 SQ. FT.  
REV: MDL 05/08/12

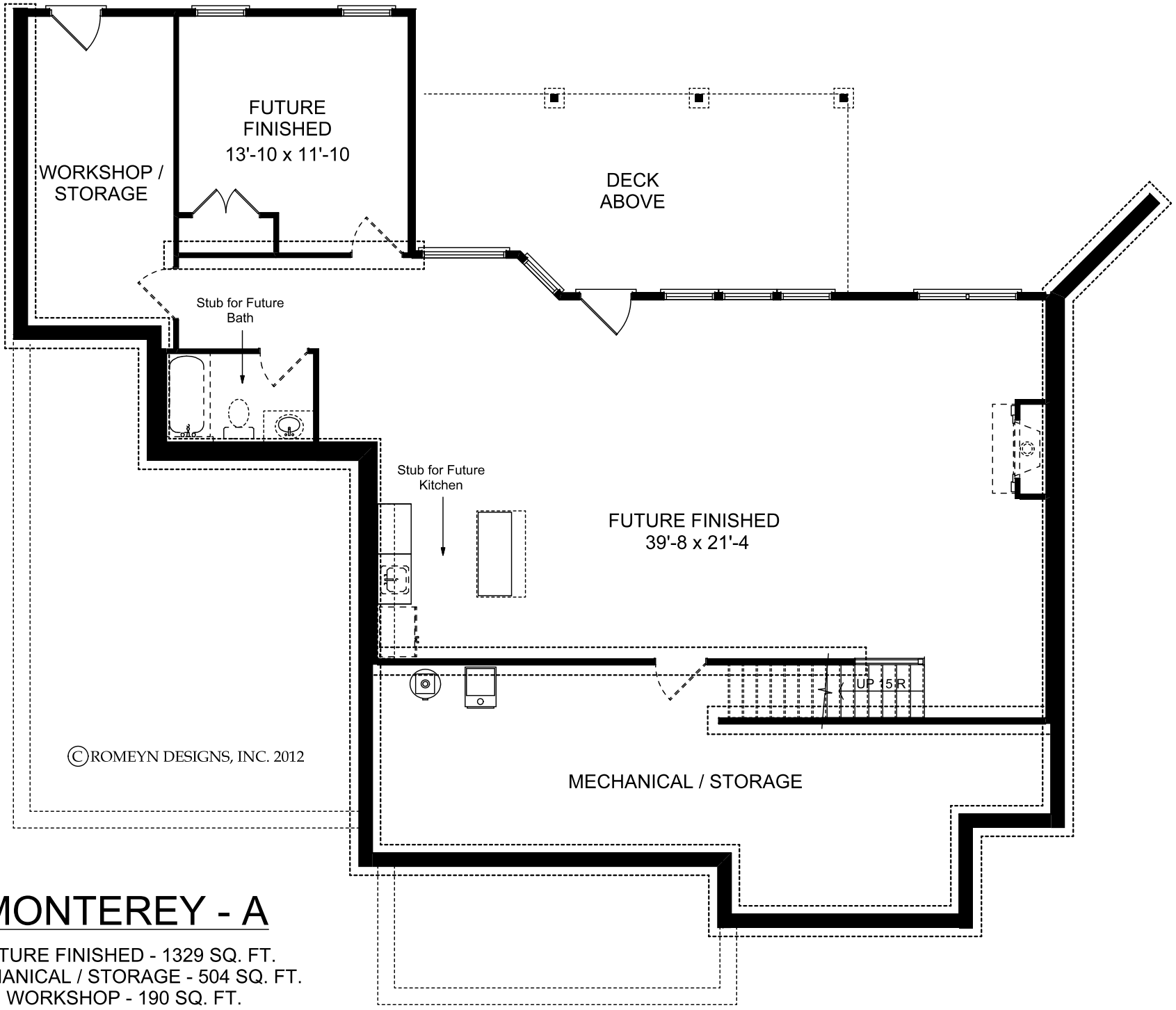

©ROMEYN DESIGNS, INC. 2012

# MONTEREY - A

FUTURE FINISHED - 1329 SQ. FT.  
MECHANICAL / STORAGE - 504 SQ. FT.  
WORKSHOP - 190 SQ. FT.  
REV: MDL 05/24/12

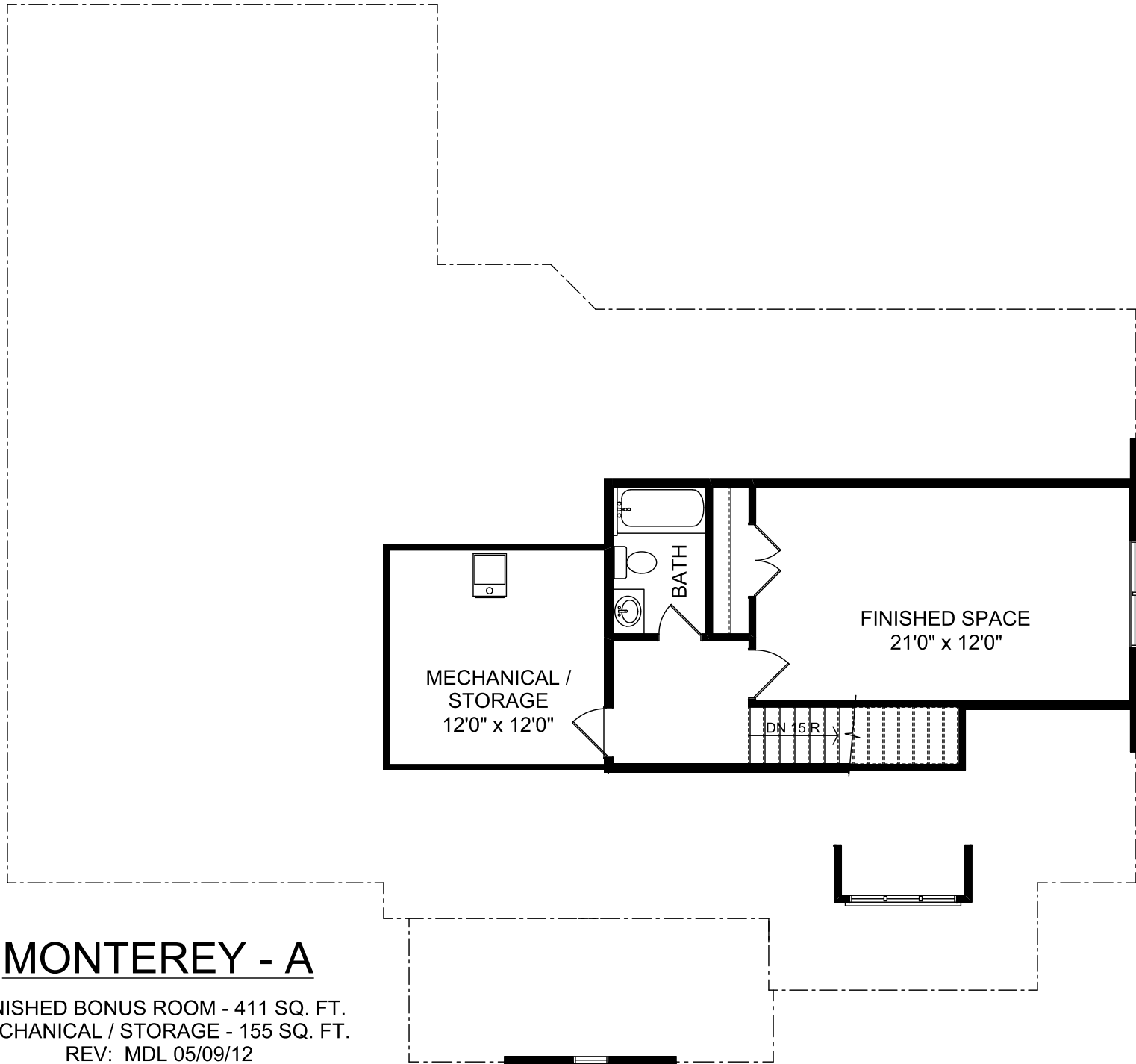

# MONTEREY - A

FINISHED BONUS ROOM - 411 SQ. FT.  
MECHANICAL / STORAGE - 155 SQ. FT.  
REV: MDL 05/09/12